

Spindle axis ELGT for cantilever systems

FESTO

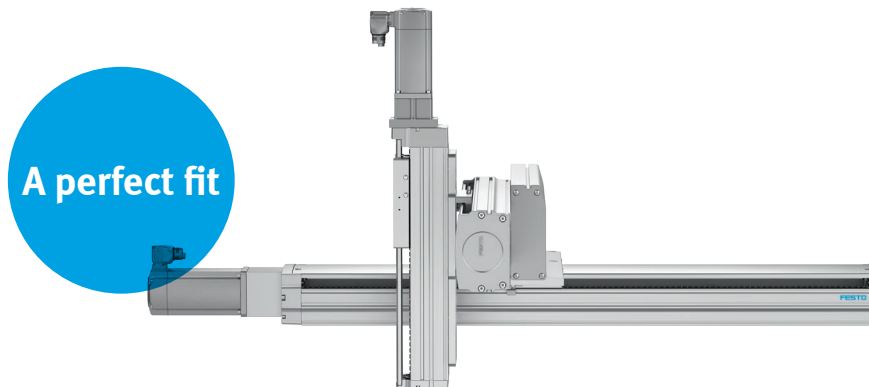

Top price & output!

Highlights

- Optimal: cantilever systems in 2D and 3D
- Open: servo drive solutions from Festo or third parties
- Combinable: for a greater variety of applications
- Flexible: simple and customer-friendly mounting options
- Economical: best value for money

The compact and low-cost spindle axes ELGT with integrated double guide are perfect for integrating into 2D and 3D cantilever systems. They have been developed for a wide range of applications, whether in the electronics industry, in desktop applications or in battery manufacturing, where they can be easily combined with axes ELGC and mini slide EGSC. Or they can be used in test and inspection systems, in small parts handling or in assembly systems.

Sophisticated technology for outstanding performance

The high load carrying capacity and rigidity provided by the integrated double guide and the extremely sturdy connectors make the ELGT ideal for high payloads and strokes of up to 1400 mm. For example, as a 3D cantilever system it can transport up to 20 kg at speeds of up to 0.5 m/s. A copper and zinc content of less than 1% means it can also be used in battery manufacturing.

Economical in combination – versatile in use

The ELGT becomes even more economical when combined with the axes ELGC or the mini slide EGSC as a Z-axis for vertical movements. Installation is easy thanks to the compatible adapter kits for all Festo servo motors and many Asian and European motor providers as well as the adapter kit for opto-electrical sensors commonly found on the market in Asia, for example from Omron. Position sensing is cost-effective and easy using inductive proximity sensors.

Spindle axis ELGT for cantilever systems

Spindle axis ELGT as a cantilever system at a glance

Hard cover design

Adapter kits for servo motors from Festo and many Asian and European third-party motors

Free choice of motor positions (turned 4 x 90°), can also be changed at a later date

Mounting bracket and mounting plate

- For precision joining of the axes
- Very lightweight yet extremely sturdy connectors

Mounting options

- Direct mounting (direct screw connection)
- Mounting via slot nuts
- Mounting via mounting bracket on the side (same as for type ELGC)

Double guide of the axis slide for size 120/160
Extra-wide individual guide of the axis slide for size 90

Lubrication nipples for separate lubrication of the guide cassettes and screw spindles

Cost-effective and simple position sensing

- Inductive proximity sensors SIES-8M and SME/SMT-8 mounted directly in the slot
- Adapter kit for opto-electrical sensors commonly found on the market in Asia, for example from Omron

Mini slide EGSC-BS

- Precise Z-axis for very good positioning accuracy combined with high load capacity

Spindle axis ELGC-BS and toothed belt axis ELGC-TB

- Protected linear axes for Y and Z movements
- Smooth-running spindle axis for precise movements
- Toothed belt axis for dynamic movements, even with heavy loads
- Protection through internal guide and permanent stainless steel cover strip

Important technical data at a glance

Technical data	Size 90	Size 120	Size 160
Working stroke (in 50 mm increments) [mm]	50 ... 1000	100 ... 1100	100 ... 1400
Spindle pitch [mm]	10/20		
Max. feed force [N]	340/175	700/350	1050/260
Max. speed [m/s]	0.5/1		
Repetition accuracy [mm]	+/- 0.02		
Horizontal payload ⁽¹⁾ [kg]	50/18	115/56	234/114
Vertical payload ⁽¹⁾ [kg]	50/18	39/18	80/38
Payload dynamic response in 3D ⁽²⁾ [kg]	20		

⁽¹⁾ Max. acceleration 2.5 m/s² with 10 mm spindle pitch and 5 m/s² with 20 mm spindle pitch

⁽²⁾ Acceleration max. 3 m/s², speed max. 0.5 m/s, working stroke max. 900 x 600 x 300